

Series 1000T10

Horizontally Split Cover Couplings

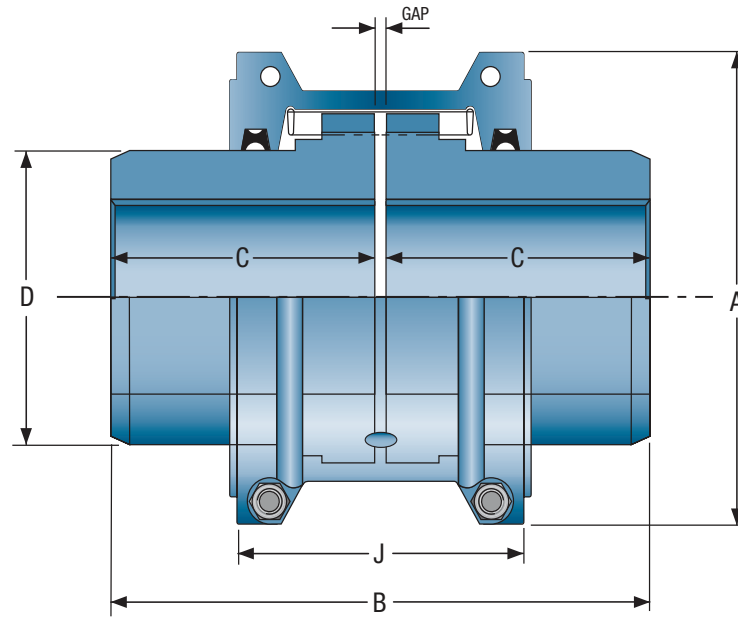

Dimensions

SIZE	COUPLING RATING (IN-LBS)	MAX SPEED	MIN BORE (IN)**	MAX BORE (IN)*	CPLG WT. (LBS)*	WR ² / (LB/FT ²)	DIMENSIONS IN INCHES					
							A	B	C	D	J	GAP
1020	460	4500	0.50	1.13	4.00	4.80	4.02	3.86	1.87	1.56	2.64	0.13
1030	1,319	4500	0.50	1.38	5.30	7.50	4.37	3.86	1.87	1.94	2.68	0.13
1040	2,204	4500	0.50	1.63	7.10	11.30	4.65	4.13	2.00	2.25	2.76	0.13
1050	3,850	4500	0.50	1.88	11.50	23.90	5.43	4.88	2.37	2.63	3.11	0.13
1060	6,054	4350	0.75	2.13	15.70	41.00	5.94	5.12	2.50	3.00	3.62	0.13
1070	8,798	4125	0.75	2.50	22.30	61.50	6.38	6.14	3.00	3.44	3.74	0.13
1080	18,144	3600	1.06	3.00	39.00	153.80	7.64	7.13	3.50	4.13	4.57	0.13
1090	33,013	3600	1.06	3.50	54.00	268.90	8.39	7.87	3.87	4.87	4.80	0.13
1100	55,582	2440	1.63	4.00	91.00	615.10	9.88	9.69	4.75	5.59	6.14	0.19
1110	82,489	2250	1.63	4.50	118.20	922.60	10.63	10.20	5.00	6.31	6.42	0.19
1120	121,255	2025	2.38	5.00	173.50	1742.70	12.13	12.01	5.87	7.06	7.56	0.25
1130	176,129	1800	2.63	6.00	260.10	3382.90	13.66	12.99	6.37	8.56	7.68	0.25
1140	253,130	1650	2.63	7.25	388.00	6321.60	15.12	14.76	7.25	10.00	7.91	0.25
1150	360,220	1500	4.25	8.00	502.60	11925.70	17.83	14.65	7.20	10.63	10.71	0.25
1160	496,500	1350	4.75	9.00	683.40	19887.50	19.76	15.83	7.80	12.01	10.94	0.25
1170	660,000	1225	5.25	10.00	987.70	35606.20	22.32	17.24	8.50	14.02	12.09	0.25
1180	915,160	1100	6.00	11.00	1364.60	62532.90	24.80	19.06	9.41	15.51	12.64	0.25
1190	1,207,000	1050	6.00	12.00	1710.80	89323.00	26.61	20.63	10.24	17.20	12.80	0.25
1200	1,645,000	900	7.00	13.00	2330.30	148609.70	29.80	22.24	11.02	19.61	14.02	0.25

* Coupling weight and WR² with no bore

** Max bores is for hub with keyway for rectangular key

Other couplings available are spacer and half spacer models.